

Well Flow Management

Well Testing | Measurement

Liquid Metering

The accurate metering of liquids flowed during well test operations is critical to providing concise well data with which to evaluate reservoir properties, estimate field commerciality and plan production systems.

There are three main techniques for the measurement of liquids;

Tank storage - Gauge tanks of appropriate volume are commonly utilized for the measurement of liquids. While a very accurate method which does not require the application of correction factors, the use of tanks is generally limited to low flow rate wells. (for Gauge Tank information please refer to the Atmospheric Gauge Tank data sheet)

Volumetric - The second method is by use of volumetric counters, which give a direct indication of the volume of liquid being produced, this method however requires the counter to operate under pressure and at a raised temperature.

As a result of increased pressure, the oil may retain dissolved gas that would eventually dissipate after storage in a gauge tank. It is therefore necessary to correct for this loss of volume by applying what is termed a "Shrinkage Factor". The raised temperature effect also causes an increase in volume, which is corrected by the application of a "Volume Correction Factor".

Each meter also has physical constraints that are compensated for by a "Meter Factor". Additionally a factor is applied to compensate where oil contains any sediment and water constituents by percentage. This correction is usually amalgamated and termed basic sediment and water content (BS&W).

Mass Flow (Coriolis) - Mass flow measured at the Coriolis meter will be converted to volume using a calculated density for the mixture. The density for the mixture flowing through the meter will be determined by calculation, using measured densities obtained from the test separator for produced oil and water, and the volumetric ratio of oil to water obtained by sampling for BS&W from the test separator meter run.

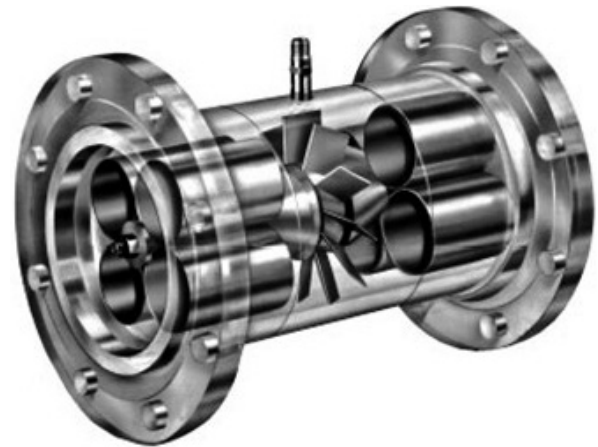

Applications

- Liquid metering and measurement

Features and benefits

- Gas and liquid dual application for Coriolis meters
- Consistent use of industry standard calculation models
- Alternative use of various meter types and configuration
- No ambiguity in data produced



Well Flow Management

Well Testing | Measurement

Liquid Metering

Technical specifications				
	Nuflo		Coriolis Mas Flow Meter	
Model	EZ-IN	CMF300	F300H	F200H
Fluid type	Oil / water	Oil / gas	Oil	Water
Density accuracy	± 0.5% of reading	+/-0.0005 g/cc	0.002, 0.001, 0.0005	0.002, 0.001, 0.0005
Wetted parts	316L SST	316L SST	Nickel alloy C22	Nickel alloy C22
Temperature range ° F (° C)	-67 to 250 (-55 to 121)	-20 to 100 (-29 to 38)	-40 to 140 (-40 to 60)	-40 to 140 (-40 to 60)
Pressure rating psi (bar)	ASA 600 1,480 to 1,235 (102 to 85) ASA 900 2,220 to 1,855 (153 to 128)	1,450 (100)	2,160 (149)	2,160 (149)
Meter size range inches (mm)	See below table	3 (75)	3 (75)	2 (50.8)
Nominal flowrate lbs/hr (kgs/hr)	N/A	0 to 361,020 (0 to 163,755)	0 to 294,000 (0 to 133,356)	0 to 115,020 (0 to 52,160)
Maximum flowrate lbs/hr (kgs/hr)	See below table	0 to 598,200 (0 to 272,000)	0 to 524,640 (0 to 238,499)	0 to 192,000 (0 to 87,100)
ATEX classification	N/A	CE 0575 II 2G EEx ib IIB T1-T5	CE 0575 II 2G Ex ib IIB T1-T6	

Linear flow range - Nuflo EZ-IN

Flow meter size			Flow capacity		Nominal calibration factor		Maximum output frequency	P at maximum flow	
in.	mm	GPM	m ³ /HR	BPD	Pulses gallon	Pulses x 1000/m ³	Pulses/sec	psi	kpa
3/8	10	0.3 - 3	0.068 - 0.68	10 - 100	22000	(5812)	1100	4.0	28
1/2	13	0.75 - 7.5	0.17 - 1.70	25 - 250	14500	(3830)	1815	12.0	83
3/4	19	2-15	0.45 - 3.41	68 - 515	2950	(780)	740	18.0	124
7/8	22	3 - 30	0.68 - 6.81	100 - 1000	2350	(621)	1175	20.0	138
1	25	5 - 50	1.14 - 11.36	170 - 1700	900	(238)	750	20.0	138
1 - 1/2	38	15 - 180	3.41 - 40.88	515 - 6000	325	(86)	975	16.0	110
2	51	40 - 400	9.09 - 90.85	1300 - 13,000	55	(14.5)	365	22.0	152
3	76	80 - 800	18.16 - 181.66	2750 - 27,500	57	(15.2)	760	20.0	138
4	102	100 - 1200	22.71 - 272.55	3400 - 41,000	30	(7.9)	600	10.0	69
6	152	250 - 2500	56.78 - 567.82	8600 - 86,000	7	(1.8)	290	10.0	6
8	203	350 - 3500	79.49 - 794.94	12,000 - 120,000	3	(.8)	175	6.0	41

The Expro Global Standard for Flow Calculations, **INS-006444**, details all relevant information regarding Expro calculation standards and methodology.

Note: Other sizes, configurations and pressure ratings are available to meet most applications, for more information contact your local Expro representative or email welltesting@expro.com

expro.com/welltesting

Date 05/2022 | Revision 1.0