

## Surface Test Tree

**The surface test tree (STT) is designed to control direction of flow in and out of the well,** allow running of various tools inside the string through coiled tubing or wire line, allow well kill, and to allow transition between the vertical test string and the surface test equipment. The size and number of components in the STT depends on the type of test being performed and the rig that is used. The minimum equipment required is a lift sub, STT block, swivel and crossover.

The STT incorporates a central body containing the following:

- Four gate valves – a master, a swab, a kill and a hydraulically actuated (normally closed) flow valve
- Flow and kill valves can be supplied with fail-safe actuator
- A swivel situated below the central body to allow tubing rotation for manipulating down hole equipment
- A lifting sub to allow rig elevators to raise and lower the tree in the derrick

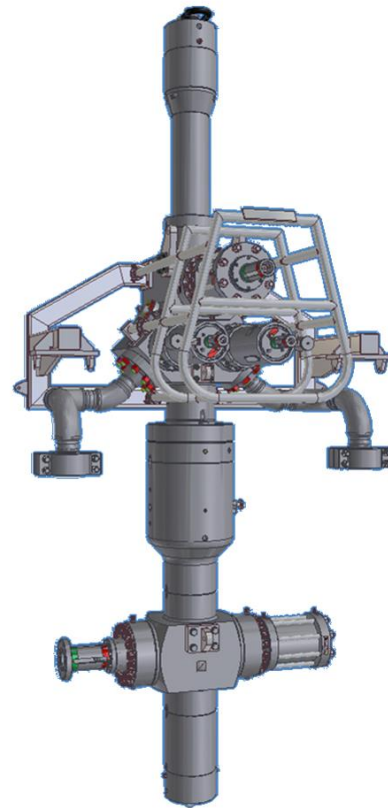

### Features and benefits

Additional components can be added to provide flexibility

The flow valve is normally hydraulically actuated to the fail safe close position and controlled from the ESD panel, thus ensuring a fast shut-down response time

Third-party certified in accordance with relevant design codes

Provides immediate flow shut-in if downstream equipment fails

Tensile load allows test string to be hung from the elevator

Swivel allows manipulation of the string without rotating the STT

Allow well intervention tools to be run into the well through the swab valve

Automatically closes flow valve if control pressure lost

### Applications

Onshore and offshore well testing

Drill stem testing

Clean-up operation

Well simulation

### Technical specifications

Size	Working pressure (PSI)	Working temp (°F)	End connections				Design code
			Top	Bottom	Flow	Kill	
3 1/16"	10K	-20 to 250	5 3/4"-4 Stub Acme	5 3/4"-4 Stub Acme	Fig 1502 hammer union	Fig 1502 hammer union	API 6A, ANSI B31.3, NACE MR-01-75, PSL 3
3 1/16"	15K	-20 to 350	5 3/4"-4 Stub Acme	5 3/4"-4 Stub Acme	H4 - 27 Techlock hub	H4 - 27 Techlock hub	API 6A, ANSI B31.3, NACE MR-01-75, PSL 3
5 1/8"	10K	-20 to 250	7 1/2"-4 Stub Acme	7 1/2" -4 Stub Acme	Fig 1502 hammer union	Fig 1502 hammer union	API 6A, ANSI B31.3, NACE MR-01-75, PSL 3
2 9/16"	15K	-20 to 250	5" -4 Stub Acme	5" -4 Stub Acme	H4 - 27 Techlock hub	H4 - 27 Techlock hub	API 6A, ANSI B31.3, NACE MR-01-75, PSL 3
7 3/8"	10K	-50 to 400	10"-4 Stub Acme	10"-4 Stub Acme	Fig 1502 hammer union	Fig 1502 hammer union	API 6A, ANSI B31.3, NACE MR-01-75, PSL 3
5 3/8"	10K	-50 to 400	8 1/4" -4 Stub Acme	8 1/4" -4 Stub Acme	Fig 1502 hammer union	Fig 1502 hammer union	API 6A, ANSI B31.3, NACE MR-01-75, PSL 3

Note: Other sizes, configurations and pressure ratings are available to meet most applications. For more information contact your local Expro representative or email [welltesting@exprogroup.com](mailto:welltesting@exprogroup.com)