

### High pressure flexible hose

The high pressure flexible hose is generally used for 10,000 psi and 15,000 psi applications to replace hard piping where any expansion in the work string, and movement when on semi-submersible rigs or drill ships may occur.

They are used to convey fluids to and from the surface test tree, to the rest of the surface test package or kill pumps, or stimulation package.

Numerous laboratory test programs and extensive field experience in a wide variety of applications have consistently proven that the high pressure flexible hoses are not affected by the constant cyclical nature of their service condition.

High crush resistance is inherent in the basic structure. Additional stainless steel outer wrap protection is provided.

The hose is resistant to bending, including frequent or continuous flexing with the imperative condition that the minimum bend radius is not exceeded.

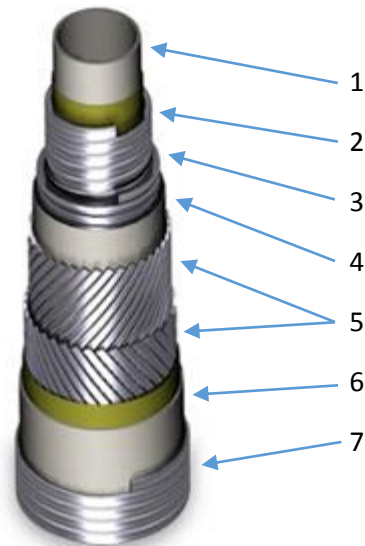

1. Thermoplastic inner liner
2. Zeta spiral
3. Flat steel spiral
4. Thermoplastic intermediate sheath
5. Cross-wound tensile armours
6. Thermoplastic external sheath
7. Outer wrap interlocked steel carcass

#### Features and benefits

Suitable for service with all types of diphasic and monophasic crude oils, methanol, glycol etc due to good corrosion resistance

H<sub>2</sub>S and CO<sub>2</sub> resistant

Suitable for a wide variety of applications (oil production, water injection, gas lift, stimulation etc)

Inner thermoplastic layer helps prevent scaling

Inner thermoplastic layer shows better resistance to wear than steel.

#### Applications

Onshore and offshore oil and gas well testing and clean-up operations:

- crude production
- water injection
- gas lift etc

### Technical specifications

Nominal diameter	Max. working pressure	Test pressure	Weight in air empty	API integral flanges	Integral clamp HUB connections		
					ID	Seal ring	Clamp #
inches	psi	psi	kg/m				
2"	5,000	10,000	23	API 6B 2-1/16"-5000 for R or RX 24	2-1/16"	R or RX 24	1
3"	5,000	10,000	34	API 6B 3-1/8"-5000 for R or RX 35	3-1/8"	R or RX 35	4
4"	5,000	10,000	44	API 6B 4-1/16"-5000 for R or RX 39	3-1/16"	R or RX 39	5
2"	10,000	15,000	32	API 6BX 2-1/16"-10000 for BX 152	2-1/16"	BX 152	2
2-1/2"	10,000	15,000	37	API 6BX 2-9/16"-10000 for BX 153	2-9/16"	BX 153	4
3"	10,000	15,000	42	API 6BX 3-1/16"-10000 for BX 154	3-1/8"	BX 154	5
4"	10,000	15,000	57	API 6BX 4-1/16"-10000 for BX 155	4-1/16"	BX 155	6
2"	15,000	22,500	32	API 6BX 2-1/16"-15000 for BX 152	2-1/16"	BX 152	3
2-1/2"	15,000	22,500	37	API 6BX 2-9/16"-15000 for BX 153	2-9/16"	BX 153	3
3"	15,000	22,500	42	API 6BX 3-1/16"-15000 for BX 154	3"	BX 154	6

Note: Other sizes, configurations and pressure ratings are available to meet most applications. For more information contact your local Expro representative or email [welltesting@exprogroup.com](mailto:welltesting@exprogroup.com)